

ELECTROMECHANICAL
UNIVERSAL ROTARY TABLES
FIBROTOR®

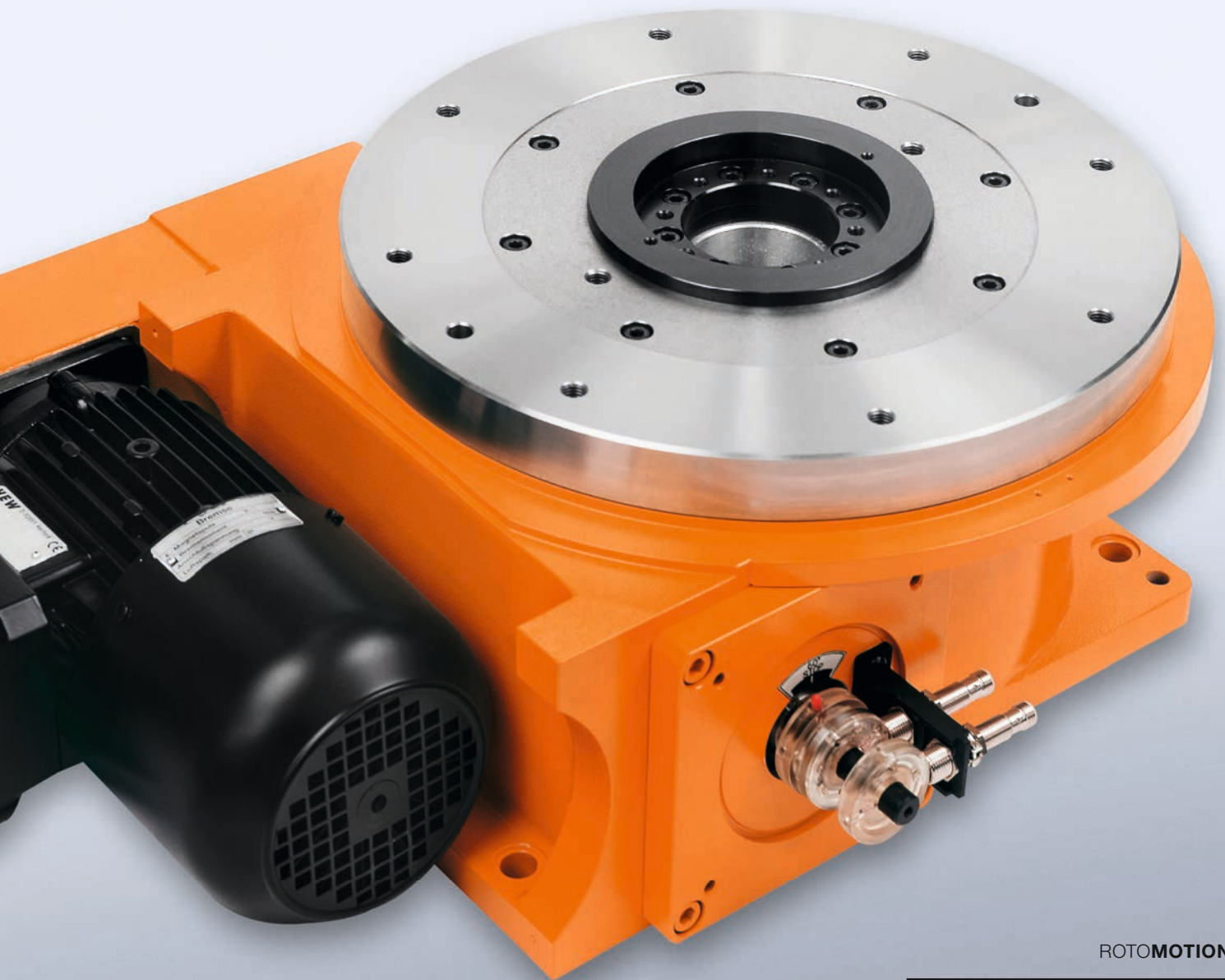

ROTOMOTION

Rotary Tables for Automation Systems

NO ONE WILL DELIVER FASTER OR PROVIDE GREATER RELIABILITY

THEY HAVE IT ALL: AN EXTREMELY LONG LIFE TIME AND SHORTEST CYCLE TIMES WITH AN EXCELLENT PRECISION AND NO NEED FOR MAINTENANCE – THESE ARE IMPORTANT ASPECTS OF ANY PRODUCTION LINE. FIBROTOR® ROTARY TABLES COMBINE ALL OF THEM, OFFERING A WARRANTY PERIOD OF UP TO FIVE YEARS AS AN ADDITIONAL HIGHLIGHT.



Highest Energy Efficiency

Thanks to its energy-efficient control cam, energy consumption drops by 20%. Alternatively, higher mass can be moved, shorter indexing time can be realised, or a smaller rotary table can be used. This is possible as a result of an optimised control cam in line with the energy efficiency formula. In the process, the service life of these rotary tables amounts to 20,000 hours MTTF (Mean Time To Failure).

FIBROTOR® rotary tables may be used as assembly tables, welding, positioning or storing tables, in packaging, printing, labelling or laser machines, as well as for chipping. FIBROTOR® rotary tables work without the elastic drive elements that tend to be worn down and enable highly precise positioning and repeatability. Extremely short positioning times ensure excellent productivity.

A large degree of standardisation and a consistent modular design allow us to deliver FIBROTOR® rotary tables with very short turnarounds.

For an optimal simulation of your system, please download all CAD data from www.fibro.com

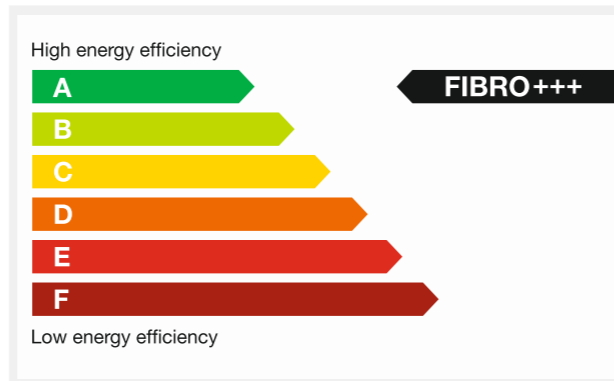

FIBROTOR®

OUR TECHNICAL HIGHLIGHTS YOUR COMPETITIVE EDGE

TECHNICAL HIGHLIGHTS

- Highest transport loads with the shortest indexing times thanks to energy-efficient design and large dimensioned axial needle bearing
- Enormous rigidity and optimum crash behaviour due to cam rollers with friction bearings
- Hardened and ground control cam provides best transfer of power and optimum motion sequence
- Low follow-up costs thanks to lifetime lubrication for minimum maintenance
- Available with numerous additional options for different assembly and application possibilities

UNIVERSAL POSITIONING FOR

- General drive tasks, e.g. driving chain belts, as a control gear or as a storing table
- Transporting and supplying tasks, e.g. for assembly, packaging, printing, labelling and riveting applications
- Chipping, e.g. deburring, honing, drilling and light milling
- Non-machining processing, e.g. lasing, welding and bending

THREE STANDARD MODELS TO SUIT ANY JOB

A vast range of products

With the FIBROTOR® product range, FIBRO offers you the rotary-table type that suits the application at hand. FIBRO provides highly accurate solutions, specifically designed to satisfy each customer's requirements, from the FIBROTOR® EM line, or an attractively priced universal rotary table from the FIBROTOR® ER line, which serves as a great basic model and can be supplied at short notice thanks to a maximum degree of standardisation. The rotary indexing ring FIBROTOR® RT is perfect for any application that requires a centre hole. All FIBROTOR® rotary tables can be used horizontally and vertically.

FIBROTOR®

FIBROTOR® EM AND EM.NC PROPERTIES

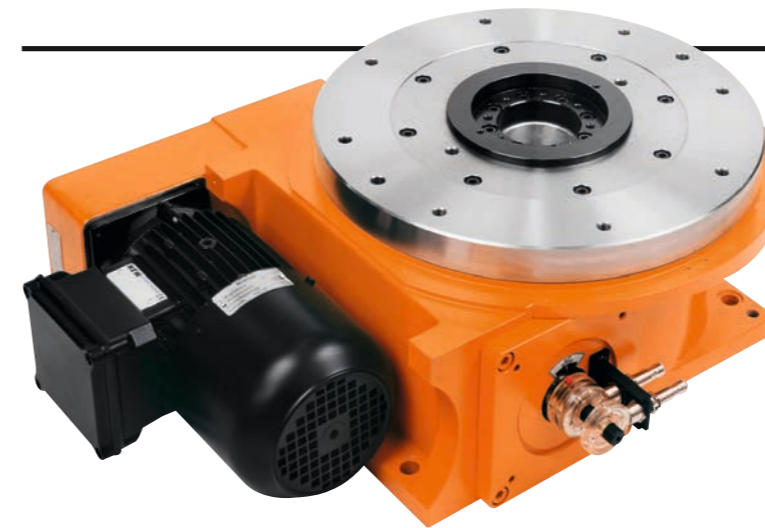

- Premium model of the FIBROTOR® universal rotary table with fixed division or for flexible positioning
- Custom manufacturing according to your individual application requirements
- Higher accuracies and shorter indexing times
- Air purge connection for all sizes

FIBROTOR® ER PROPERTIES

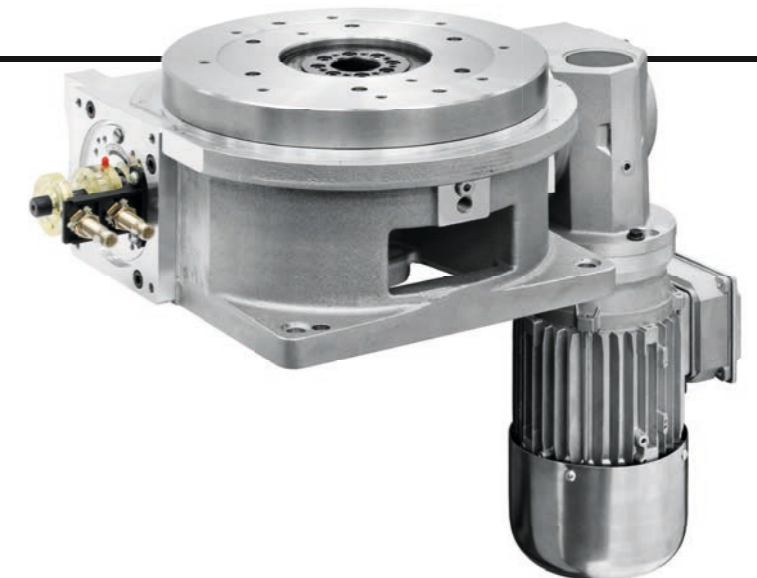

- Cost-optimised, standardised FIBROTOR® model
- Shorter delivery times compared to FIBROTOR® EM

FIBROTOR® RT AND RT.NC PROPERTIES



- The rotary table with a large centre hole
- FIBROTOR® RT can also be supplied as an RT.NC model for flexible positioning

ADDITIONAL OPTIONS FOR ALL FIBROTOR® PRODUCTS

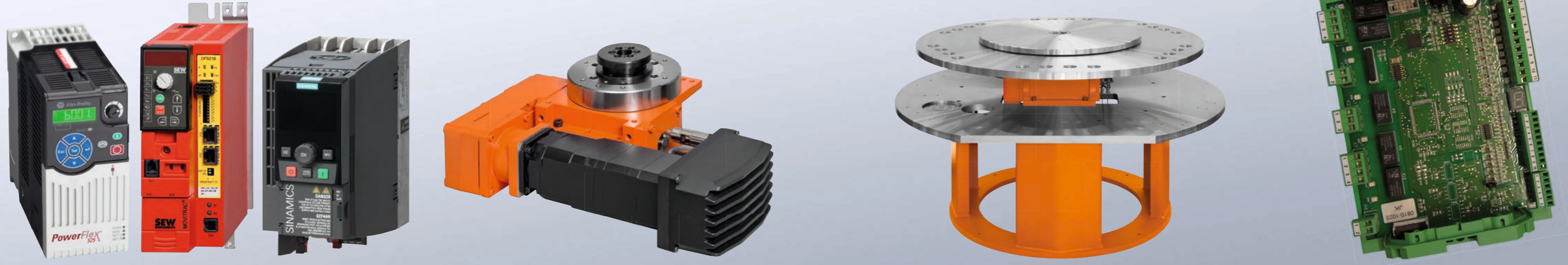

FREQUENCY INVERTER WITH FIBRO SOFTWARE

- 5-year warranty!
- Pre-programmed sequences, such as CW, CCW rotation or pendulum mode, soft start, specifically after emergency stop, rapid speed and creeping speed
- Optimisation of indexing times
- Less wiring complexity
- Minimum brake wear
- Monitoring of the three-phase brake motor

FIBRODRIVE plus

- AC servomotor with integrated controller
- Autonomous operation – intelligent stand-alone solution including diagnosis function via LED
- Most simple pluggable cable connections for logic and power supply
- No implementation by the customer required
- USB connection to the terminal block
- Teach-in function
- Simple handling thanks to the intuitive program software FIBRO Servo-Link
- Matched system with decentralised connection that requires no amplifier in the control cabinet
- Safe Torque Off (STO) according to EN ISO 13849-1 performance level e

ADDITIONAL TABLE TOP AND MACHINE STAND

- Rotating additional table top, fix plates for top and bottom manufactured specifically to meet our customers' requirements
- Standard machine stands and individual solutions

FIBROTOR® MICROPROCESSOR CONTROL CARD

- Microprocessor-controlled and monitored functional sequence
- Autonomous functional sequence
- No time delay due to external cycles
- Fault monitoring
- Housing for mounting rail

On top of that, we supply centring rings as well as centring flanges for faster set up and a more precise installation of your superstructures!



SMART POSITION DETECTION
with electrical over-travel protection



MEDIA FEEDTHROUGH, POSITION DETECTION
and over-travel protection

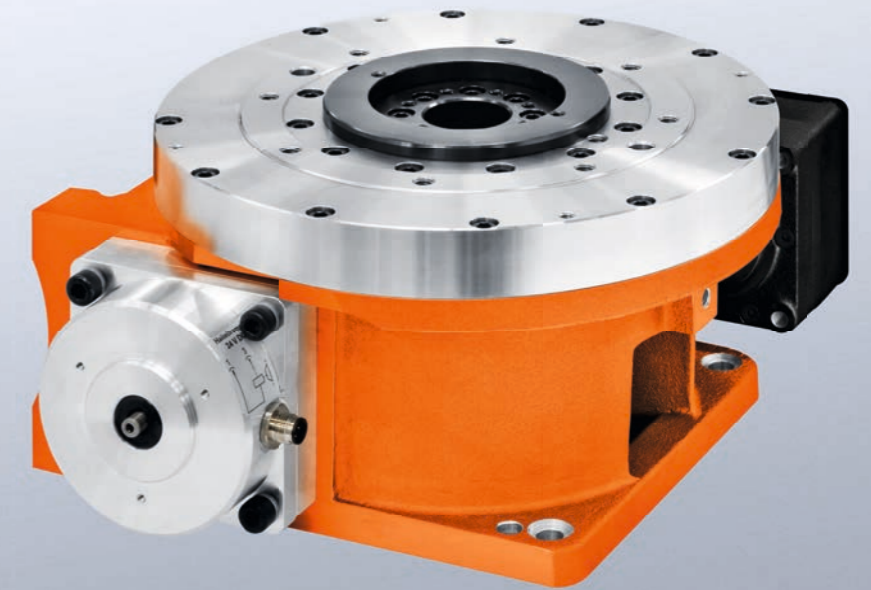

REINFORCED TABLE TOP BEARING
and hydraulic table top clamping

ADDITIONAL OPTIONS FOR FIBROTOR® EM AND EM.NC

SMART POSITION DETECTION

- Smart module for detecting the position of the table top
- Applicable as electrical over-travel protection
- Available for FIBROTOR® EM and ER
- IP65 protection class provides excellent protection from humidity and spray water
- Increases the process safety of your system

MEDIA FEEDTHROUGH, POSITION DETECTION AND OVER-TRAVEL PROTECTION

- Media feedthrough for liquid or gaseous media and electrical signals
- Position detection at table top
- Over-travel protection to avoid cable breaks during pendulum mode
- Easy cable entry thanks to lateral opening in the housing

REINFORCED TABLE TOP BEARING

- For one-sided loading or cylindrical machining to absorb the highest tilting moments
- Higher tilting moments on the positioned table top (+200%)
- Higher tilting moments on the rotating table top (+300%)

HYDRAULIC TABLE TOP CLAMPING

- When processing workpieces for the highest tangential loads
- Release of the drive elements
- Higher tangential moments (+250%)

CONSTRUCTION TYPE

THE MOST IMPORTANT DATA

		EM.10 EM.NC.10 ER.10	EM.11 EM.NC.11 ER.11	EM.12 EM.NC.12 ER.12	EM.13 EM.NC.13 ER.13	EM.14*** EM.NC.14*** ER.14***	EM.15 EM.NC.15 ER.15
Main dimensions							
Table top Ø	mm	100	160	220	280	350	410
Overall height	mm	100	100/125*	150	175	200	220
Centre hole Ø	mm	10	22*	35	35/70**	70	70
Weight approx.	kg	12	20	35	70	120	150

Load data (working position horizontal/turning axis vertical)

Perm. add-on Ø	mm	520	800	1,000	1,400	1,800	2,000
Transport load	kg	100	500	800	1,500	2,000	2,500
Perm. axial load	N	4,000	8,000	12,000	16,000	20,000	25,000
Perm. radial load	N	1,000	3,500	8,000	10,000	12,500	15,000
Perm. tilting moment in position	Nm	350	750	2,000	3,000	4,500	6,000
Perm. tilting moment rotating	Nm	100	200	600	1,000	1,500	2,000
Perm. tangential moment standard EM + ER	Nm	25	300	400	600	900	1,200
Perm. tangential moment EM.NC	Nm	25	125	200	250	300	320

Divisions

Standard divisions EM + ER		2 / 3 / 5 / 6 / 8 / 10 / 12 / 16 / 20 / 24					
EM divisions up to		48	96	96	96	96	96
EM.NC. divisions		any position					

Accuracies EM + EM.NC

EM indexing accuracy division 2–12		± 40	± 25	± 18	± 18	± 15	± 12
EM indexing accuracy division 16–24		± 50	± 40	± 25	± 25	± 22	± 20
EM indexing accuracy above division 24		± 100	± 80	± 40	± 35	± 35	± 35
EM.NC indexing accuracy direct measurement		–	± 30	± 10	± 10	± 10	± 10
EM.NC indexing accuracy indirect measurement		± 120	± 60	± 45	± 45	± 45	± 45
EM.NC indexing accuracy measurement on the motor		± 300	± 210	± 150	± 120	± 100	± 80
Axial runout (related to ø table top)	mm	0.02	0.01	0.01	0.01	0.015	0.015
Concentricity (related to ø centre hole)	mm	0.02	0.01	0.01	0.01	0.015	0.015
Plane parallelism (related to ø table top)	mm	0.04	0.02	0.03	0.03	0.03	0.04

Accuracies ER

ER indexing accuracy division 2–12		± 60	± 40	± 35	± 30	± 25	± 20
ER indexing accuracy division 16–24		± 70	± 50	± 40	± 35	± 30	± 25
Axial runout (related to ø table top)	mm	0.02	0.015	0.02	0.02	0.025	0.03
Concentricity (related to ø centre hole)	mm	0.02	0.015	0.02	0.02	0.025	0.03
Plane parallelism (related to ø table top)	mm	0.04	0.03	0.04	0.04	0.05	0.06

Additional options EM + EM.NC

Perm. tilting moment w. strengthened bearing in position	Nm	–	2,250	6,000	9,000	13,500	18,000
Perm. tilting moment w. strengthened bearing rotating	Nm	200	600	1,800	3,000	4,500	6,000
Perm. tangential moment with table top clamping	Nm	–	450	800	900	1,200	1,800

* for division 02, overall height 125 mm, eccentric centre hole ** division 02–05 ø 35 mm, from division 06 and EM.NC ø 70 mm

Subject to technical changes

		EM.16 EM.NC.16 ER.16	EM.17 EM.NC.17 ER.17	EM.18 EM.NC.18	RT.12 RT.NC.12	RT.13 RT.NC.13	RT.0750 RT.NC.0750
Main dimensions							
Table top Ø	mm	460	558	750	360	460	654
Overall height	mm	270	380	420	65	65	95
Centre hole Ø	mm	110	130	180	170	270	440
Weight approx.	kg	220	450	850	50	80	230

Load data

Perm. add-on Ø	mm	2,400	2,800	3,500	2,000	2,200	3,000
Transport load	kg	4,000	5,500	6,400	400	500	800
Perm. axial load	N	32,000	70,000	100,000	12,000	15,000	5,000
Perm. radial load	N	20,000	25,000	36,000	8,000	10,000	8,000
Perm. tilting moment in position	Nm	9,000	12,000	18,000	2,000	2,200	2,250
Perm. tilting moment rotating	Nm	3,000	4,000	6,000	600	660	750
Perm. tangential moment standard EM + ER + RT	Nm	1,400	1,600	2,500	400	500	2,400
Perm. tangential moment EM.NC + RT.NC	Nm	500	700	800	200	250	2,000

Divisions

Standard divisions EM + ER + RT		2 / 3 / 5 / 6 / 8 / 10 / 12 / 16 / 20 / 24****					
EM divisions + RT divisions up to		96	130	130	36	36	30
EM.NC. + RT.NC divisions		any position					

Accuracies EM + EM.NC + RT. + RT.NC

EM indexing accuracy division 2–12		± 12	± 10	± 10	± 12 (T 4-20)	± 12 (T 6-20)	–
EM indexing accuracy division 16–24		± 18	± 15	± 15	± 18 (T 22-36)	± 18 (T 22-36)	± 12 (T 4-30)
EM indexing accuracy above division 24		± 30	± 25	± 25	± 30 (above T36)	± 30 (above T36)	± 18 (above T30)
EM.NC indexing accuracy direct measurement		± 10	± 10	± 10	–	–	–
EM.NC indexing accuracy indirect measurement		± 30	± 30	± 30	± 30	± 30	± 30
EM.NC indexing accuracy measurement on the motor		± 60	± 50	± 40	± 120	± 90	± 40
Axial runout (related to ø table top)	mm	0.015	0.02	0.02	0.03	0.04	0.05
Concentricity (related to ø centre hole)	mm	0.015	0.02	0.02	0.03	0.04	0.04
Plane parallelism (related to ø table top)	mm	0.04	0.04	0.04	0.06	0.08	0.05

Accuracies ER

ER indexing accuracy division 2–12		± 20	± 20	–	–	–	–
ER indexing accuracy division 16–24		± 25	± 25	–	–	–	–
Axial runout (related to ø table top)	mm	0.03	0.04	–	–	–	–
Concentricity (related to ø centre hole)	mm	0.03	0.04	–	–	–	–
Plane parallelism (related to ø table top)	mm	0.06	0.08	–	–	–	–

Additional options EM + EM.NC

Perm. tilting moment w. strengthened bearing in position	Nm	27,000	36,000	54,000	–	–	–
Perm. tilting moment w. strengthened bearing rotating	Nm	9,000	12,000	18,000	–	–	–
Perm. tangential moment with table top clamping	Nm	1,900	2,500	4,000	–	–	–

*** available 2018 **** RT.12 small division 04 not available, RT.13 small division 06 not available

FIBRO RUNDTISCHE GMBH

Weidachstraße 41-43 74189
Weinsberg GERMANY
T +49 7134 73-0
info@fibroRT.com
www.fibroRT.com

BRANCHOFFICES

FIBRO INC.

139 Harrison Avenue
Rockford, IL 61104
USA
T +1 815 2291300
info@fibroinc.com
www.fibroinc.com

